

ADVERTISED COPY

QuantumTraffic

Quantum Traffic Pty Ltd

ABN 54617474370

ACN 617474370

T 1300 757 016

E admin@quantumtraffic.com.au

A 5 Murray Place
RINGWOOD VIC 3143

W www.quantumtraffic.com.au

Traffic Impact Assessment Report

7-9 Nicholson Court, Clayton

Proposed Residential Development

25/05/2022





Traffic Impact Assessment Report

7-9 Nicholson Court, Clayton

Proposed Residential Development

Prepared for the Applicant: Pitard Group

Document Control

Revision	Date	Reference	Prepared By	Approved By
A (Draft)	18/05/22	2021-0080	N.C.	D.B.
A (Final)	25/05/22	2021-0080	N.C.	D.B.

QuantumTraffic

Quantum Traffic Pty Ltd

ABN: 54617474370

ACN: 617474370

Copyright © 2017- by Quantum Traffic Pty Ltd

All rights reserved. No part of this publication may be reproduced, distributed, or transmitted in any form or by any means, including photocopying, recording, or other electronic or mechanical methods, without the prior written permission of the publisher, Quantum Traffic.

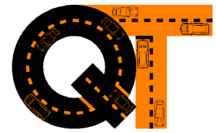

Executive Summary

This report assesses the proposed residential development at 19-23 Central Avenue, Moorabbin. The following provides an executive summary of the report.

Car Parking

The statutory car parking requirement as specified under Clause 52.06-5 of the Monash Planning Scheme is 37 car spaces.

The application has provision for 37 car parking spaces, therefore meeting the statutory car parking requirements of Clause 52.06 of the Monash Planning Scheme.

The design standards of the car parking layout and access arrangements are principally in accordance with Clause 52.06 of the Monash Planning Scheme and is therefore expected to provide convenient and functional car parking and access for residents.

Bicycle Parking

The proposed development has a statutory requirement to provide 9 bicycle parking spaces under Clause 52.34 of the Monash Planning Scheme. The application has provision for 12 bicycle spaces, exceeding the statutory bicycle parking requirement. Bicycle spaces have been designed in accordance with AS2890.3-2015.

Traffic Impacts

The proposal is projected to generate in the order of 19 traffic movements during peak periods. Development traffic is expected to be assimilated by the road network without adverse impact to the operation and performance of Nicholson Street and the broader road network.

Service Vehicles

Loading will at times be undertaken by residents when moving into and out of the proposed apartments, which can satisfactorily be undertaken off-site, or informally on-site with utes and vans.

Waste collection arrangements will be addressed by a WMP. On-site waste collection could be undertaken on-site by an MRL, with the basement car park designed to allow a nominal 6.4m MRL to enter and exit the site in a forward direction.

Summary of Opinions

Having undertaken all tasks necessary to adequately assess the traffic engineering impacts of the proposed residential development, we are of the view that there are no traffic engineering reasons that should preclude the issue of a permit, subject to appropriate conditions.

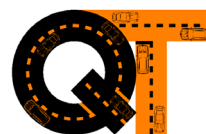

Table of Contents

Executive Summary	iii
1 Introduction	3
2 Proposed Development	3
3 Existing Conditions	3
3.1 Subject Site	3
3.2 Road Network	6
3.3 Public Transport	7
3.3.1 Walking & Cycling Infrastructure	9
4 Car Parking Assessment	11
4.1 Statutory Car Parking	11
5 Car Park Design	12
6 Bicycle Parking Assessment	15
7 Traffic Considerations	16
7.1 Traffic Generation	16
7.2 Traffic Distribution	16
8 Loading & Commercial Vehicle Arrangements	18
8.1 Loading	18
8.2 Waste Collection	18
9 Conclusions	19

Appendices

Appendix A: Proposed Development Plans

Appendix B: Swept Path Diagrams



Figures

Figure 1: Aerial Photograph (source: Nearmap)	5
Figure 2: Location Map (Source: www.melway.com.au).....	6
Figure 3: Nicholson Street – View North	7
Figure 4: Nicholson Street – View South	7
Figure 5: PPTN Zoning Map (Source: VicPlan).....	7
Figure 6: Public Transport Local Area Map (Source: www.ptv.com.au)	8
Figure 7: Monash TravelSmart Map	10

Tables

Table 1: Proposed Development Numbers	3
Table 2: Existing Features of Subject Site	4
Table 3: Public Transport Infrastructure	9
Table 5: Statutory Car Parking Assessment.....	11
Table 6: Review of Car Park Design - Clause 52.06-9	12
Table 7: Statutory Bicycle Parking Assessment.....	15
Table 8: Traffic Distribution	17



1 Introduction

The following Traffic Impact Assessment Report, reviews the car parking and traffic matters of the proposed residential development at 7-9 Nicholson Court, Clayton.

The application proposes to redevelop the site for a residential apartment building and has been assessed with consideration to the relevant statutory requirements of the Monash Planning Scheme.

2 Proposed Development

The proposal seeks to redevelop the site for a multi-storey residential development at 7-9 Nicholson Court, Clayton.

Table 1 outlines the key attributes of the development from a traffic engineering perspective.

Table 1: Proposed Development Numbers

Attribute	Proposal
Land Use	
Dwellings	1-bed – 3 No. 2-bed – 24 No. 3-bed – 5 No. Total – 32 dwellings
Car Parking Provision	
Basement Level	37 car spaces
Bicycle Parking	
Ground	5 bicycle spaces
Basement Level	7 bicycle spaces

A bin store is proposed within basement, with collection arrangements to be determined by a waste management plan (WMP).

Development Application Plans prepared by Pitard Group are attached at Appendix A.

3 Existing Conditions

3.1 Subject Site

The proposed development site is generally rectangular in shape, comprising of 2 land parcels (No. 7 and 9). The site is located on the west side of Nicholson Court at the street's terminus (Melway Reference 79 C2).

Table 2 outlines the key existing features of the development site.

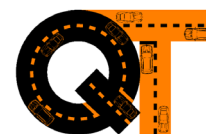

Table 2: Existing Features of Subject Site

Site Feature	Detail
Municipality & Referral Authorities	
Municipality	Monash City Council
Existing Use	
7 Nicholson Court	Single dwelling, single width driveway and parking at the rear
9 Nicholson Court	Single dwelling, single width driveway and parking at the rear
Zoning & Overlays	
Zoning	Residential Growth Zone – Schedule 3 (RGZ3)
Overlays	Special Building Overlay (SBO)
Critical Dimensions	
Total Site Area	Approx. 1,390m ²
Existing On-Site Car Parking	
7-9 Nicholson Court	Open-air car spaces provided within driveways and setback area.
On-Street Car Parking	
Nicholson Court (West Side)	4P 8:00AM-6:00PM Mon-Sat authorised vehicles excepted
Nicholson Court (East Side)	No stopping
Nearby Land Use	
Within 200m	Clayton Road Activity Centre Meade Reserve Clayton Railway Station

An aerial photograph and location map are provided at Figure 1 to Figure 2, respectively.



Figure 1: Aerial Photograph (source: Nearmap)

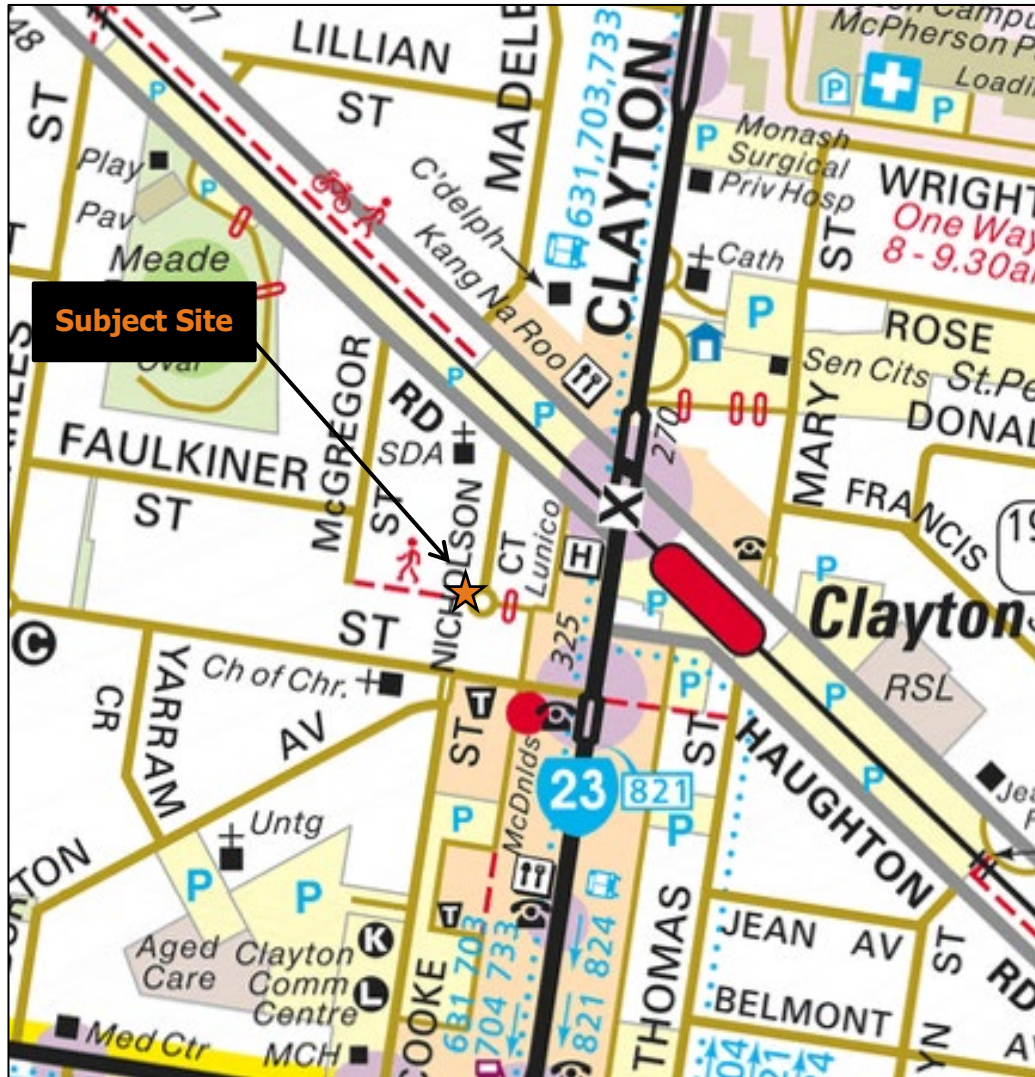
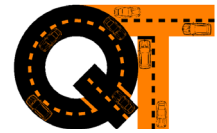

Figure 2: Location Map (Source: www.melway.com.au)

3.2 Road Network

Nicholson Court

Nicholson Court is a local access road under the management of Monash City Council. Aligned generally in a north to south direction, Nicholson Court extends southwards and terminates in a cul-de-sac approximately 120m south from Haughton Road.

Adjacent the subject site, Nicholson Court is constructed with an approximate carriageway width of 7.3m and operates with two-way traffic and car parking on the west side of the road. The court bowl, adjacent No. 9 Nicholson Court has an approximate diameter of 11.0m and is restricted to 'No Stopping'.

Car parking along the east side of Nicholson Street is generally restricted to 4P 8:00AM-6:00PM Monday to Saturday, whilst 'No Stopping' restrictions apply on the west side. Footpaths are provided on both sides of Central Avenue.

The default built-up urban speed limit of 50km/hr applies to Nicholson Street, adjacent the subject site.

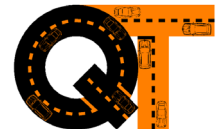

Photographs of the existing conditions on Central Avenue are shown in Figure 3 and Figure 4 below.



Figure 3: Nicholson Street – View North

Figure 4: Nicholson Street – View South

3.3 Public Transport

The subject site is highly accessible to public transport infrastructure with several services within proximity to the subject site. This is demonstrated by the site's positioning within the Principal Public Transport Network (PPTN), as illustrated in Figure 5 following.

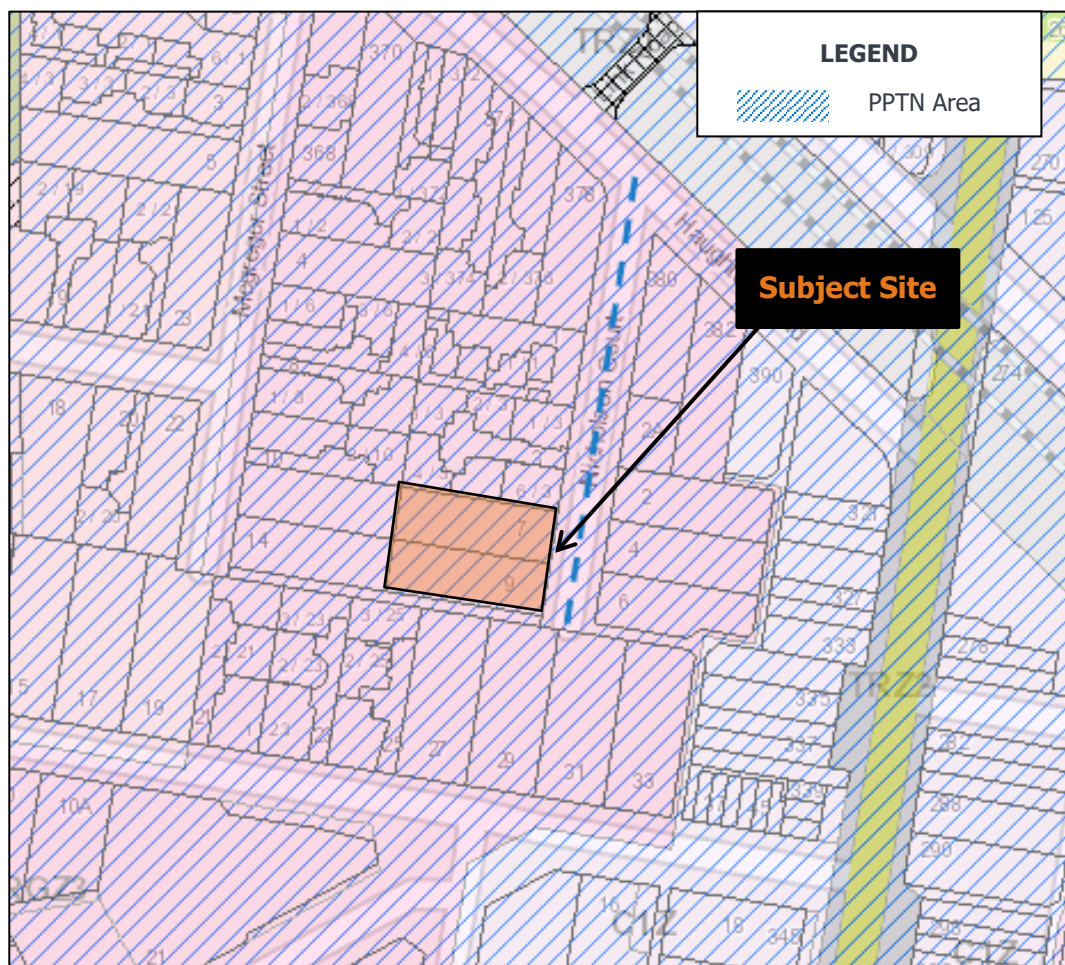
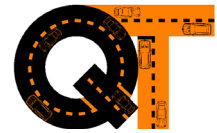

Figure 5: PPTN Zoning Map (Source: VicPlan)



The surrounding bus and rail services provide a connection to major retail precincts and shopping centres, as well as the city and other day to day destinations.

Figure 6 illustrates the nearby public transport services, and an itinerary of the public transport services operating in proximity to the subject site is summarised at Table 3.

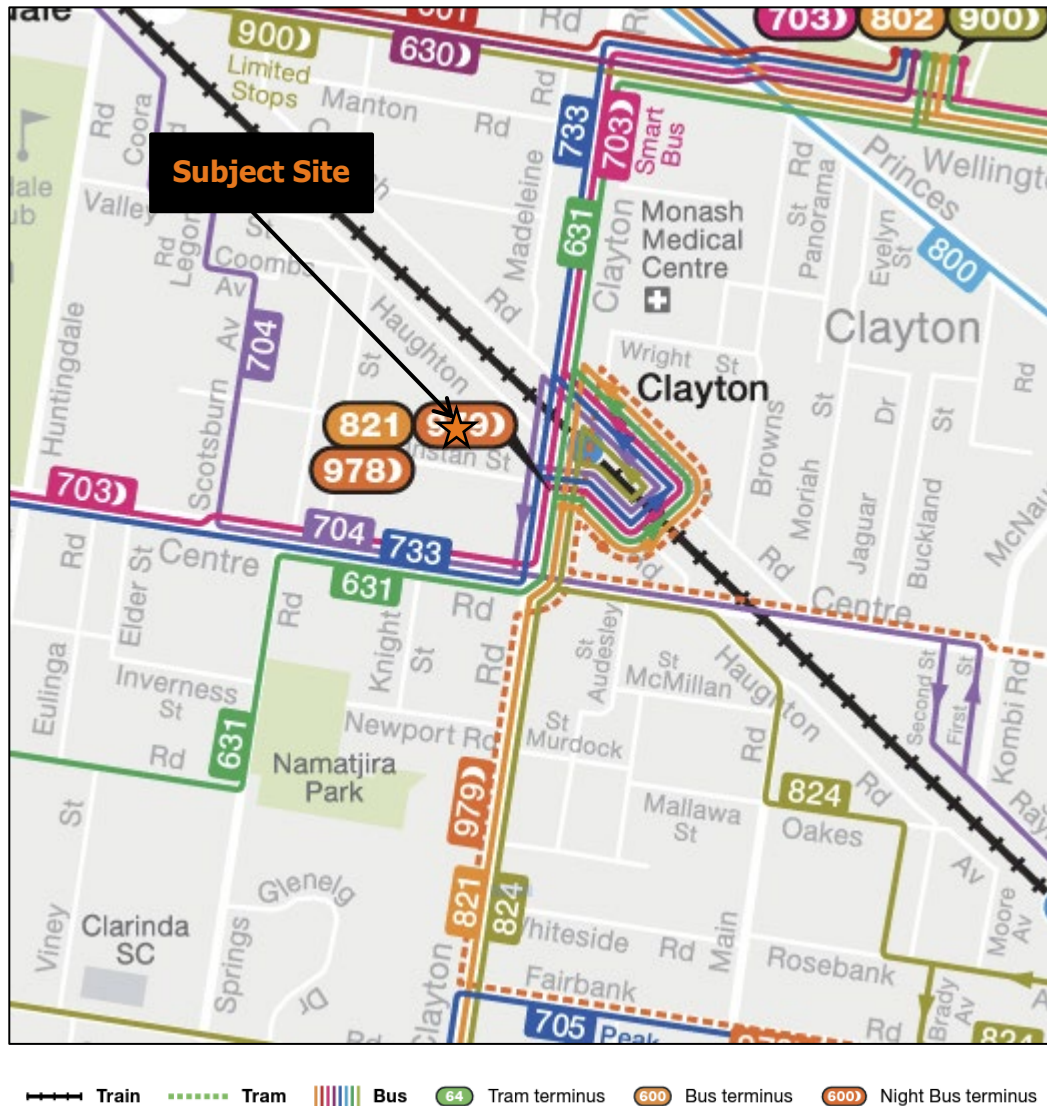

Figure 6: Public Transport Local Area Map (Source: www.ptv.com.au)



Table 3: Public Transport Infrastructure

Service	Between	Via	Operation by Period		
			Weekdays	Saturday	Sunday
Buses					
Route 733	Oakleigh-Box Hill	Clayton & Monash University	Y	Y	Y
Route 821	Southland-Clayton	Heatherton	Y	N	N
Route 631	Southland-Waverley Gardens	Clayton & Monash University	Y	Y	Y
Route 704	Oakleigh Station-Westall	Clayton	Y	Y	Y
Route 703	Middle Brighton-Blackburn	Bentleigh, Clayton & Monash University	Y	Y	Y
Train					
Cranbourne /Pakenham Train Line	Melbourne CBD to Cranbourne/Pakenham	Richmond & Caulfield	Y	Y	Y

3.3.1 Walking & Cycling Infrastructure

The subject site has access to the surrounding walking and bicycle network.

Access to nearby cycling facilities is available via the Nicholson Court frontage which provides access to the Djerring Trail. A map illustrating the bicycle network surrounding the site is provided at Figure 7.



Figure 7: Monash TravelSmart Map

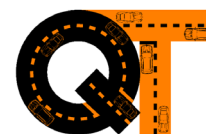

4 Car Parking Assessment

4.1 Statutory Car Parking

Clause 52.06-5 of the Monash Planning Scheme prescribes the number of car spaces to be provided for the proposed development.

Under Clause 74 of the Planning Scheme, the proposed residential apartments are defined as 'Dwellings'.

Of relevance, Clause 52.06-5 states:

Column B applies if:

- any part of the land is identified as being within the Principal Public Transport Network Area as shown on the Principal Public Transport Network Area Maps (State Government of Victoria, August 2018); or
- a schedule to the Parking Overlay or another provision of the planning scheme specifies that Column B applies.

In this case, the site is located within the PPTN area, and is not subject to a car parking overlay; therefore, the Column B rates in Table 1 of Clause 52-06-5 apply.

Table 4 outlines an assessment of the car parking provision against the statutory requirement prescribed under Clause 52.06-5 of the Monash Planning Scheme.

Table 4: Statutory Car Parking Assessment

Use	No.	Statutory Car Parking Rate	Req.	Provision	+/-
Dwellings					
1 bedroom	3	1 space per dwelling	3	3	-
2 bedrooms	24		24	25	+1
3 bedrooms	5	2 spaces per dwelling	10	10	-
Visitors	32	-	-	-	-
TOTAL			37	37	-

Based on the above assessment, the proposed development has a statutory car parking requirement to provide 37 car spaces. The proposal has provision for 37 car spaces, meeting the statutory car parking requirements of Clause 52.06 of the Planning Scheme.

Accordingly, a car parking permit to vary the statutory car parking requirement is not sought by the application.

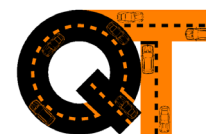

5 Car Park Design

The proposed basement car park is proposed to/from Nicholson Court, via a single lane accessway with passing area at the entrance.

The following table reviews the proposed car parking design against the design standards of Clause 52.06-9 of the Monash Planning Scheme.

Table 5: Review of Car Park Design - Clause 52.06-9

Design Standard	Compliant	Comments
Design Standard 1 - Accessways		
<i>Be at least 3 metres wide</i>	Exceeded	The proposed accessway is proposed to be at least 3.6m wide between walls.
<i>Have an internal radius of at least 4 metres at changes of direction or intersection or be at least 4.2 metres wide.</i>	Compliant	The internal accessways are greater than 4.2m at changes of direction, and or swept paths appropriately demonstrate the functionality of the proposed access design.
<i>Allow vehicles parked in the last space of a dead-end accessway in public car parks to exit in a forward direction with one manoeuvre</i>	Not Applicable	The proposed car park will not be public in nature. Nevertheless, spaces located at the end of a dead-end accessway have been designed to allow a vehicle to appropriately exit car parking spaces. Swept path diagrams have been prepared demonstrating accessibility of a typical end space.
<i>Provide at least 2.1 metres headroom beneath overhead obstructions, calculated for a vehicle with a wheel base of 2.8 metres</i>	Compliant	The proposed car park will provide at least 2.2m headroom clearance in all trafficable areas.
<i>If the accessway serves four or more car spaces or connects to a road in a Transport Zone 2 or Transport Zone 3, the accessway must be designed so that cars can exit the site in a forward direction</i>	Compliant	The application has provision for more than 4 car spaces, therefore the car park has been designed to allow exit manoeuvres in a forward direction.
<i>Provide a passing area at the entrance at least 6.1 metres wide and 7 metres long if the accessway serves ten or more car parking spaces and is either more than 50 metres long or connects to a road in a Transport Zone 2 or Transport Zone 3</i>	Not Applicable	The accessway is not greater than 50m in length nor does it connect to a road in a Transport Zone.

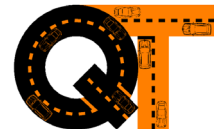

Design Standard	Compliant	Comments
<i>Have a corner splay or area at least 50 per cent clear of visual obstructions extending at least 2 metres along the frontage road from the edge of an exit lane and 2.5 metres along the exit lane from the frontage, to provide a clear view of pedestrians on the footpath of the frontage road</i>	Compliant	The sight splay provided on the north side of the entrance measuring 2.5m along the accessway, and 2.0m along the boundary is provided, satisfying this requirement. The ramp is offset approximately 1.2m from the southern boundary, providing a level of sight distance. Given the entrance is grading down towards the footpath, drivers are expected to have sufficient sight distance to the south of the access ramp.
<i>If an accessway to four or more car parking spaces is from land in a Transport Zone 2 or Transport Zone 3, the access to the car spaces must be at least 6 metres from the road carriageway</i>	Not Applicable	The proposed access is not taken from a road within a Road 2 or Road Zone 3. Nevertheless, car parking spaces are located more than 6m away from the road carriageway.
<i>If entry to the car space is from a road, the width of the accessway may include the road</i>	Not Applicable	All spaces are accessed via an internal accessway.
Design Standard 2 – Car Parking Spaces		
<i>Car parking spaces and accessways must have the minimum dimensions as outlined in Table 2.</i>	Compliant	All standard car spaces have minimum dimensions of 2.6m width and 4.9m depth, accessible from aisles that are 6.4m wide. Where aisle narrow to 5.8m, car spaces have been widened to 2.8m, in accordance with the Planning Scheme.
<i>A wall, fence, column, tree, tree guard or any other structure that abuts a car space must not encroach into the area marked 'clearance required' on Diagram 1, other than:</i> <ul style="list-style-type: none"> <i>A column, tree or tree guard, which may project into a space if it is within the area marked 'tree or column permitted' on Diagram 1.</i> <i>A structure, which may project into the space if it is at least 2.1 metres above the space.</i> 	Principally Compliant & Acceptable Variation	All car spaces adjacent an obstruction have been provided with a 300mm clearance. Columns have been located 250mm-1250mm from the aisle end of car spaces. On the basis of the preceding, convenient door opening and pedestrian accessibility around parked vehicles is provided.
<i>Car spaces in garages or carports must be at least 6 metres long and 3.5 metres wide for a single space and 5.5 metres wide for a</i>	Not Applicable	No garage spaces are proposed.

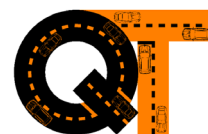

Design Standard	Compliant	Comments
<i>double space measured inside the garage or carport.</i>		
<i>Where parking spaces are provided in tandem (one space behind the other) an additional 500 mm in length must be provided between each space</i>	Satisfied	Tandem spaces have been provided with a 500mm separation between bays.
<i>Where two or more car parking spaces are provided for a dwelling, at least one space must be under cover</i>	Compliant	All car parking spaces are provided undercover within a basement level car park.
<i>Disabled car parking spaces must be designed in accordance with Australian Standard AS2890.6-2009 (disabled) and the Building Code of Australia. Disabled car parking spaces may encroach into an accessway width specified in Table 2 by 500mm</i>	Not Applicable	DDA bays are not required for residential developments.
Design Standard 3 – Gradients		
<i>Accessway grades must not be steeper than 1:10 (10 per cent) within 5 metres of the frontage.</i>	Compliant	The first 5m of the car park entrance is no steeper than 1 in 10.
<i>Ramps (except within 5 metres of the frontage) must have the maximum grades as outlined in Table 3 and be designed for vehicles travelling in a forward direction.</i>	Compliant	The access ramp is proposed with a maximum grade of 1 in 4.
<i>Where the difference in grade between two sections of ramp or floor is greater than 1:8 (12.5 per cent) for a summit grade change, or greater than 1:6.7 (15 per cent) for a sag grade change, the ramp must include a transition section of at least 2 metres to prevent vehicles scraping or bottoming.</i>	Compliant	Ramp grade changes are no steeper than 12.5% and 15% for crest and sag grade changes, respectively. Scraping and bottoming are therefore appropriately prevented for B99 design vehicles.
<i>Plans must include an assessment of grade changes of greater than 1:5.6 (18 per cent) or less than 3 metres apart for clearances, to the satisfaction of the responsible authority.</i>	Not Applicable	Grade changes do not exceed 18%.

Based on the above design standard assessment, we are satisfied the proposed car parking layout and vehicle access arrangements to are satisfactory and acceptably meet the objectives of Clause 52.06-9 of the Monash Planning Scheme, and where applicable, AS2890.1-2004.

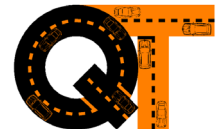

6 Bicycle Parking Assessment

Clause 52.34-2 of the Monash Planning Scheme sets out the provisional requirements for bicycle parking. A Clause 52.34-3 assessment for the application is provided at Table 6 following.

Table 6: Statutory Bicycle Parking Assessment

Use	Size/ No.	Statutory Bicycle Parking Rate	Requirement (1)
Dwellings			
Residents	32 No.	1 to each 5 dwellings in developments of 4 or more storeys	6
Visitors		1 to each 10 dwellings in developments of 4 or more storeys	3
TOTAL			9 spaces

Based on the foregoing assessment, the application has a statutory requirement to provide for 9 bicycle parking spaces comprising 6 resident spaces and 3 visitor spaces.

The proposed development has provision for a total of 12 bicycle parking spaces comprising 7 secure resident spaces, and 5 bike spaces on the ground floor accessible to visitors.

The bicycle parking layout has been designed with reference to AS 2890.3:2015 – Bicycle Parking.

All spaces are provided in horizontal format and have been provided at 1.8m depth 1.0m spacings and are accessible from at least 1.5m wide aisles.

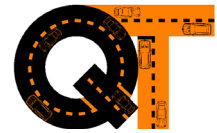

7 Traffic Considerations

7.1 Traffic Generation

Residents

To understand the level of traffic that may be generated by the proposed residential component of the development, the RTA (now RMS) Guide (October, 2002) has been sourced. The RMS Guide outlines traffic generation rates for various land uses based on extensive data collection (primarily conducted in NSW), including a range of different types of dwellings. This Guide is used by DoT and is generally accepted for developments within a metropolitan setting.

For smaller units and apartments with up to 2 bedrooms, The RMS Guide recommends a trip generation of 4-5 vehicle trip ends per day and a rate of 5-6.5 vehicle trip ends per day for larger dwellings.

Based on the location of the site, car parking provisions and the types of dwellings proposed, a conservative daily traffic generation rate of 6 movements per dwelling allocated a car space has been adopted for the purposes of the assessment. Applying this rate to the proposed development would equate to a residential traffic generation of 192 movements per day.

It is typical for 10% of these vehicle trip ends (vehicle movements) to occur in the peak hours i.e. 19 movements.

Visitors

Traffic generation associated visitors and customers to the development is expected to be dispersed throughout the broader road network, and form part of the Clayton activity centre network traffic. The traffic associated with this component of the development is unlikely to have a direct and consequential impact to the immediate road network.

7.2 Traffic Distribution

The foregoing assessment projects a traffic generation of 192 daily vehicle movements, with 19 vehicle movements occurring in the commuter peak periods (typically 8-9am and 5-6pm).

Table 7 outlines the likely distribution of entering and exiting traffic in the AM and PM peak hours. The distribution is based on the following widely accepted distributions for residential traffic.

Residential

- AM Peak hour – 80% of vehicles exiting, 20% of vehicles entering
- PM Peak Hour – 40% of vehicles exiting, 60% of vehicles entering



Table 7: Traffic Distribution

Use	No. of Movements	Avg. Time Per Movement per Peak Hour
AM Peak Hour		
Entering Movement	4	1 movement every 15 minutes
Exiting Movement	15	1 movement every 4 minutes
PM Peak Hour		
Entering Movement	11	1 movement every 5.5 minutes
Exiting Movement	8	1 movement every 7.5 minutes

The level of traffic projected to be generated by the proposed development is equivalent to a single traffic movement being generated, on average, every 3.2 minutes. This is not expected to have a discernible impact on the adjacent road network and is considered modest in traffic engineering terms.

Furthermore, Nicholson Street is sign posted as 'No Stopping' on the east side of the road, thereby improving the environmental capacity of the street.

With consideration to the projected traffic volumes, configuration of the local road network, and type of traffic projected to be generated by the proposal, the level of traffic expected to be generated by the development is not expected to cause undue impact on the prevailing traffic conditions of Nicholson Street or the surrounding road network.



8 Loading & Commercial Vehicle Arrangements

8.1 Loading

The loading demands likely to be generated by the application are expected to be minimal and associated with residents moving in and out of the dwellings.

These loading activities are generally undertaken by utes and vans which can access the basement car park. Parking for small trucks is expected to be infrequent and relatively short-term in nature, which can be facilitated on-street.

Overall, the impacts to on-street parking will be negligible because of these loading demands.

8.2 Waste Collection

Waste bins will be stored within a bin store located in the proposed basement.

A waste management plan (WMP) is likely to be prepared as part of an RFI, and likely to propose on-site collection.

On-site collection is likely to be undertaken by private waste contractor.

We anticipate the formal collection arrangements will include the use of a 6.4m long mini-rear loader (MRL). The vehicle would enter the basement carpark, manoeuvre to the bin store area, for bin collection, and then turnaround within the basement and exit the site in a forward direction.

Swept path diagrams in Appendix B have been prepared demonstrating the acceptability of the above manoeuvres by the nominal waste collection vehicle.

The above arrangements are subject to a review undertaken by a waste management consultant.



9 Conclusions

Having visited the site and undertaken a detailed traffic engineering assessment the following conclusions have been determined for the proposed residential development at 7-9 Nicholson Court, Clayton:

1. The statutory car parking requirement as specified under Clause 52.06-5 of the Monash Planning Scheme is 37 car spaces.
2. The application has provision for 37 car parking spaces, therefore meeting the statutory car parking requirements of Clause 52.06 of the Monash Planning Scheme.
3. The design standards of the car parking layout and access arrangements are principally in accordance with Clause 52.06 of the Monash Planning Scheme and is therefore expected to provide convenient and functional car parking and access for residents.
4. The proposed development has a statutory requirement to provide 9 bicycle parking spaces under Clause 52.34 of the Monash Planning Scheme. The application has provision for 12 bicycle spaces, exceeding the statutory bicycle parking requirement. Bicycle spaces have been designed in accordance with AS2890.3-2015.
5. The proposal is projected to generate in the order of 19 traffic movements during peak periods. Development traffic is expected to be assimilated by the road network without adverse impact to the operation and performance of Nicholson Street and the broader road network.
6. Loading will at times be undertaken by residents when moving into and out of the proposed apartments, which can satisfactorily be undertaken off-site, or informally on-site with utes and vans.
7. Waste collection arrangements will be addressed by a WMP. On-site waste collection could be undertaken on-site by an MRL, with the basement car park designed to allow a nominal 6.4m MRL to enter and exit the site in a forward direction.

Having undertaken all tasks necessary to adequately assess the traffic engineering impacts of the proposed residential development, we are of the view that there are no traffic engineering reasons that should preclude the issue of a permit, subject to appropriate conditions.

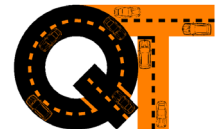

Appendix A

Proposed Development Plans

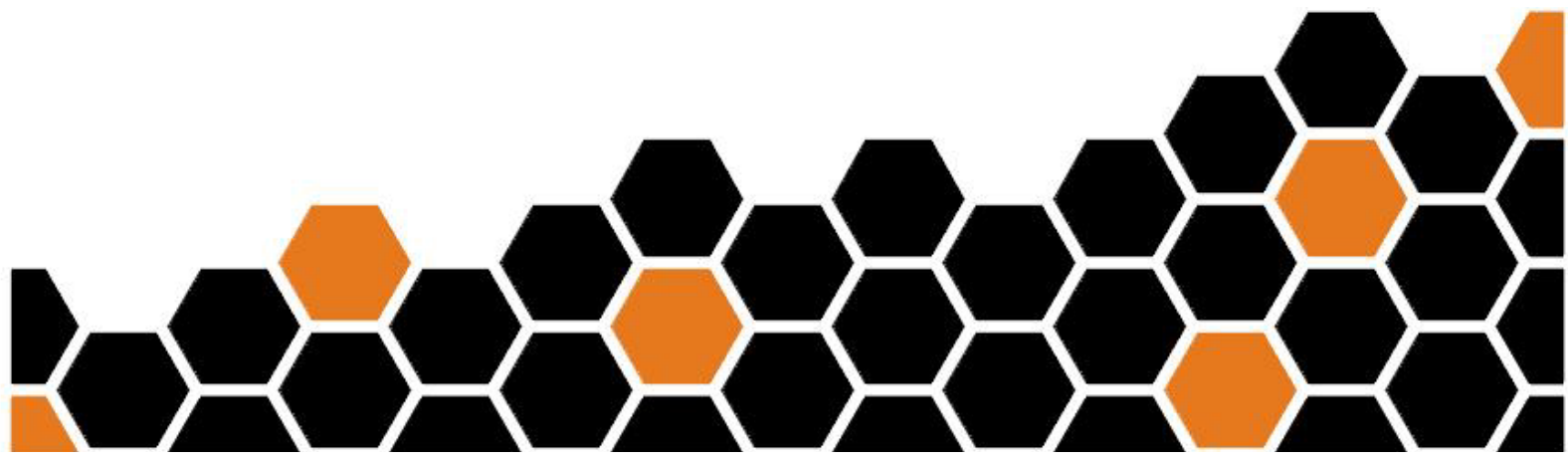

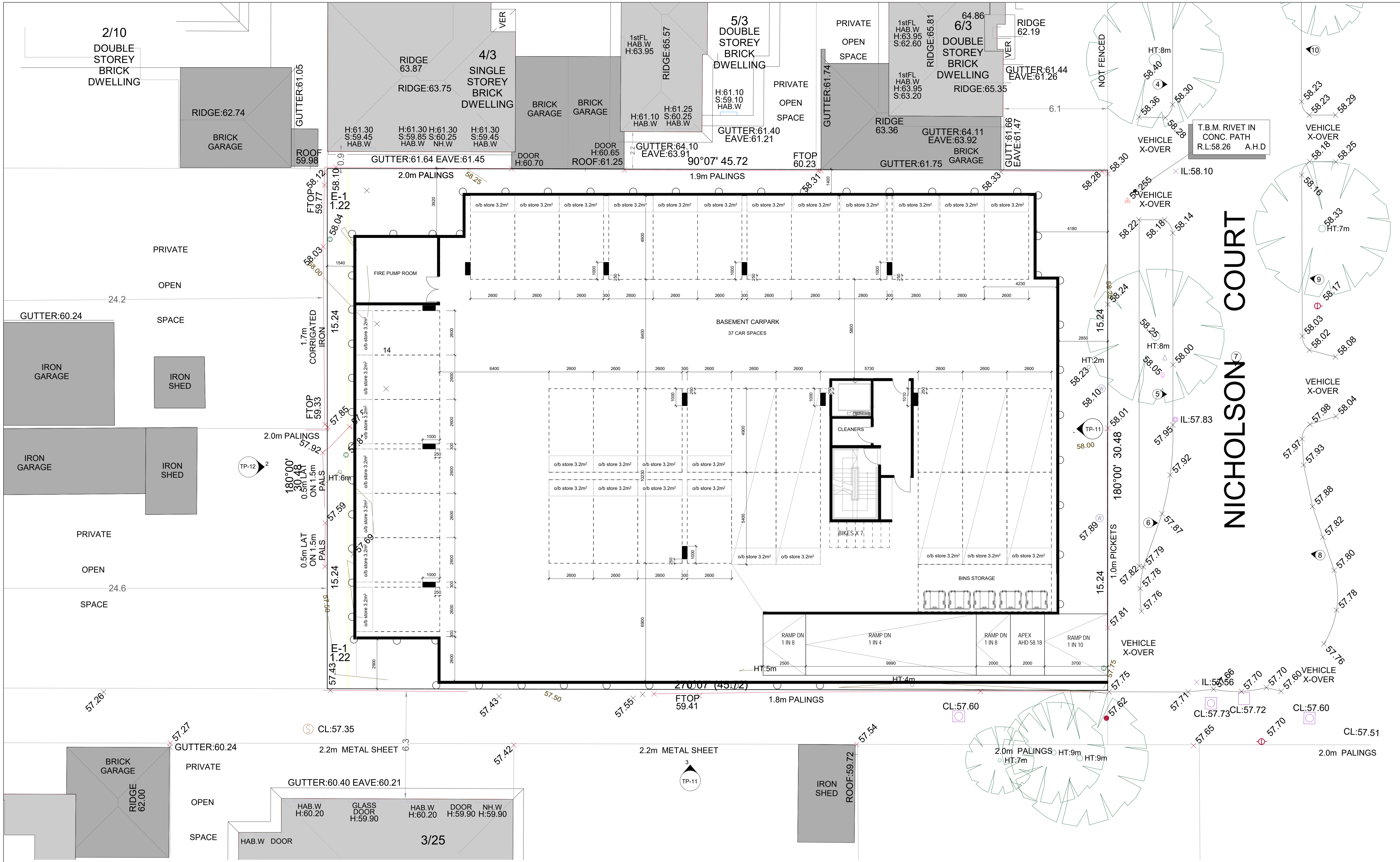

1 | Basement
1:100

COPYRIGHT - ALL RIGHTS RESERVED
 THIS DRAWING IS COPYRIGHT AND CONFIDENTIAL APART FROM ANY FAIR DEALINGS AS PERMITTED UNDER THE COPYRIGHT. NO PART MAY BE REPRODUCED BY ANY PERSONS WITHOUT WRITTEN PERMISSION OF PITARD GROUP AND IS NOT TO BE USED IN ANY MANNER PREJUDICIAL TO THIS DRAWING AND ATTACHED SHEETS REMAIN THE PROPERTY OF PITARD GROUP UNLESS OTHERWISE SPECIFIED. DIMENSIONS ARE IN MILLIMETRES. ALL DRAWING CONTENT MUST BE VERIFIED ON SITE PRIOR TO COMMENCEMENT OF ANY WORK.

No.	DATE	AMENDMENT

No.	DATE	AMENDMENT

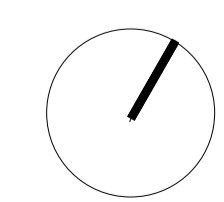

PROJECT:
7-9 Nicholson Cr Clayton
 ADDRESS:
7-9 Nicholson Cr Clayton

DRAWING:
Basement Plan

JOB NO:
2203
 SCALES:
1:100

AUTHOR:
PP
 DATE:
26-04-22

DRAWING NO:
TP-04
 A1 size sheet:
 REV:





NICHOLSON COURT

SITE AREA ANALYSIS

AREA SCHEDULE	
SITE AREA:	1394m ²
SITE COVERAGE:	944m ² (67.7%)
SITE PERMEABILITY:	278m ² (19.94%)
GARDEN AREA:	327m ² (23.45%)

Area Legend
1:50

1 Ground Floor
1:100

PITARD GROUP

COPYRIGHT - ALL RIGHTS RESERVED
THIS DRAWING IS COPYRIGHT AND CONFIDENTIAL APART FROM ANY FAIR DEALINGS AS PERMITTED UNDER THE COPYRIGHT. NO PART MAY BE REPRODUCED BY ANY PERSONS WITHOUT WRITTEN PERMISSION OF PITARD GROUP AND IS NOT TO BE USED IN ANY MANNER PREJUDICIAL TO THE DRAWING AND ATTACHED SHEETS REMAIN THE PROPERTY OF PITARD GROUP UNLESS OTHERWISE SPECIFIED. DIMENSIONS ARE IN MILLIMETRES. ALL DRAWING CONTENT MUST BE VERIFIED ON SITE PRIOR TO COMMENCEMENT OF ANY WORK.

No.	DATE	AMENDMENT

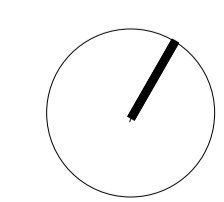

PROJECT:
7-9 Nicholson Cr Clayton
ADDRESS:
7-9 Nicholson Cr Clayton

DRAWING:
Ground Floor Plan

JOB NO:
2203
SCALES:
As indicated

AUTHOR:
PP
DATE:
26-04-22

DRAWING NO:
TP-05
A1 size sheet:

REV:



NICHOLSON COURT

1 First Floor
1:100

COPYRIGHT - ALL RIGHTS RESERVED
 THIS DRAWING IS COPYRIGHT AND CONFIDENTIAL APART FROM ANY FAIR DEALINGS AS PERMITTED UNDER THE COPYRIGHT. NO PART MAY BE REPRODUCED BY ANY PERSONS WITHOUT WRITTEN PERMISSION OF PITARD GROUP AND IS NOT TO BE USED IN ANY MANNER PREJUDICIAL TO THIS DRAWING AND ATTACHED SHEETS REMAIN THE PROPERTY OF PITARD GROUP UNLESS OTHERWISE SPECIFIED. DIMENSIONS ARE IN MILLIMETRES. ALL DRAWING CONTENT MUST BE VERIFIED ON SITE PRIOR TO COMMENCEMENT OF ANY WORK.

No.	DATE	AMENDMENT	No.	DATE	AMENDMENT

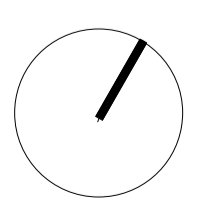

PROJECT:
7-9 Nicholson Cr Clayton
 ADDRESS:
7-9 Nicholson Cr Clayton

DRAWING:
First Floor Plan

JOB NO:
2203
 SCALES:
1:100

AUTHOR:
PP
 DATE:
26-04-22

DRAWING NO:
TP-06
 A1 size sheet:
 REV:





NICHOLSON COURT

1 Second Floor
1:100

COPYRIGHT - ALL RIGHTS RESERVED
 THIS DRAWING IS COPYRIGHT AND CONFIDENTIAL APART FROM ANY FAIR DEALINGS AS PERMITTED UNDER THE COPYRIGHT. NO PART MAY BE REPRODUCED BY ANY PERSONS WITHOUT WRITTEN PERMISSION OF PITARD GROUP AND IS NOT TO BE USED IN ANY MANNER PREJUDICIAL TO THIS DRAWING AND ATTACHED SHEETS REMAIN THE PROPERTY OF PITARD GROUP UNLESS OTHERWISE SPECIFIED. DIMENSIONS ARE IN MILLIMETRES. ALL DRAWING CONTENT MUST BE VERIFIED ON SITE PRIOR TO COMMENCEMENT OF ANY WORK

No.	DATE	AMENDMENT

No.	DATE	AMENDMENT

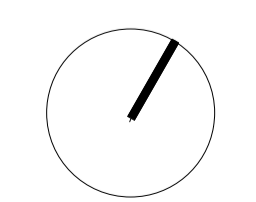

PROJECT:
7-9 Nicholson Cr Clayton
 ADDRESS:
7-9 Nicholson Cr Clayton

DRAWING:
Second Floor Plan

JOB NO:
2203
 SCALES:
1:100

AUTHOR:
PP
 DATE:
26-04-22

DRAWING NO:
TP-07
 A1 size sheet:
 REV:





PITARD GROUP

COPYRIGHT - ALL RIGHTS RESERVED
 THIS DRAWING IS COPYRIGHT AND CONFIDENTIAL APART FROM ANY FAIR DEALINGS AS PERMITTED UNDER THE COPYRIGHT. NO PART MAY BE REPRODUCED BY ANY PERSONS WITHOUT WRITTEN PERMISSION OF PITARD GROUP AND IS NOT TO BE USED IN ANY MANNER PREJUDICIAL TO THE DRAWING AND ATTACHED SHEETS REMAIN THE PROPERTY OF PITARD GROUP UNLESS OTHERWISE SPECIFIED. DIMENSIONS ARE IN MILLIMETRES. ALL DRAWING CONTENT MUST BE VERIFIED ON SITE PRIOR TO COMMENCEMENT OF ANY WORK.

No.	DATE	AMENDMENT

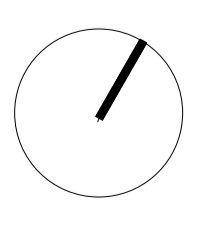

PROJECT:
7-9 Nicholson Cr Clayton

ADDRESS:
7-9 Nicholson Cr Clayton

DRAWING:
Third Floor Plan

JOB NO:
2203

SCALES:
1 : 100

AUTHOR:
PP

DATE:
26-04-22

DRAWING NO:
TP-08

REV:
A1 size sheet:

1 Third Floor
1:100

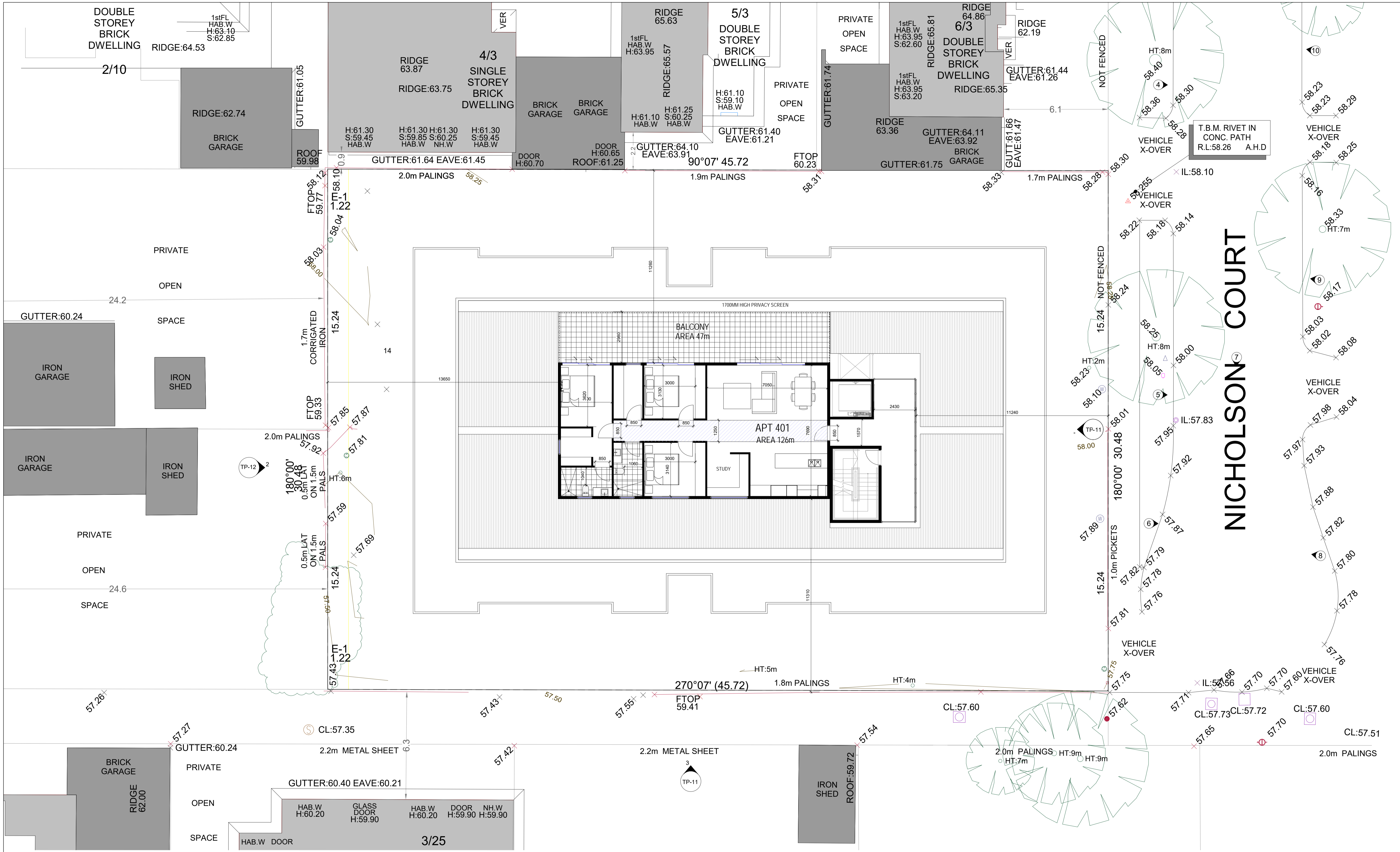

NICHOLSON COURT

1 | Fourth Floor
1 : 100

COPYRIGHT - ALL RIGHTS RESERVED
 THIS DRAWING IS COPYRIGHT AND CONFIDENTIAL APART FROM ANY FAIR DEALINGS AS PERMITTED UNDER THE COPYRIGHT. NO PART MAY BE REPRODUCED BY ANY PERSONS WITHOUT WRITTEN PERMISSION OF PITARD GROUP AND IS NOT TO BE USED IN ANY MANNER PREJUDICIAL TO THE DRAWING AND ATTACHED SHEETS REMAIN THE PROPERTY OF PITARD GROUP UNLESS OTHERWISE SPECIFIED. DIMENSIONS ARE IN MILLIMETRES. ALL DRAWING CONTENT MUST BE VERIFIED ON SITE PRIOR TO COMMENCEMENT OF ANY WORK.

No.	DATE	AMENDMENT

No.	DATE	AMENDMENT

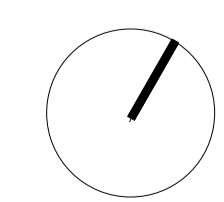

PROJECT:
7-9 Nicholson Cr Clayton
 ADDRESS:
7-9 Nicholson Cr Clayton

DRAWING:
Fourth Flor Plan

JOB NO:
2203
 SCALES:
1 : 100

AUTHOR:
PP
 DATE:
26-04-22

DRAWING NO:
TP-09
 A1 size sheet:

REV:



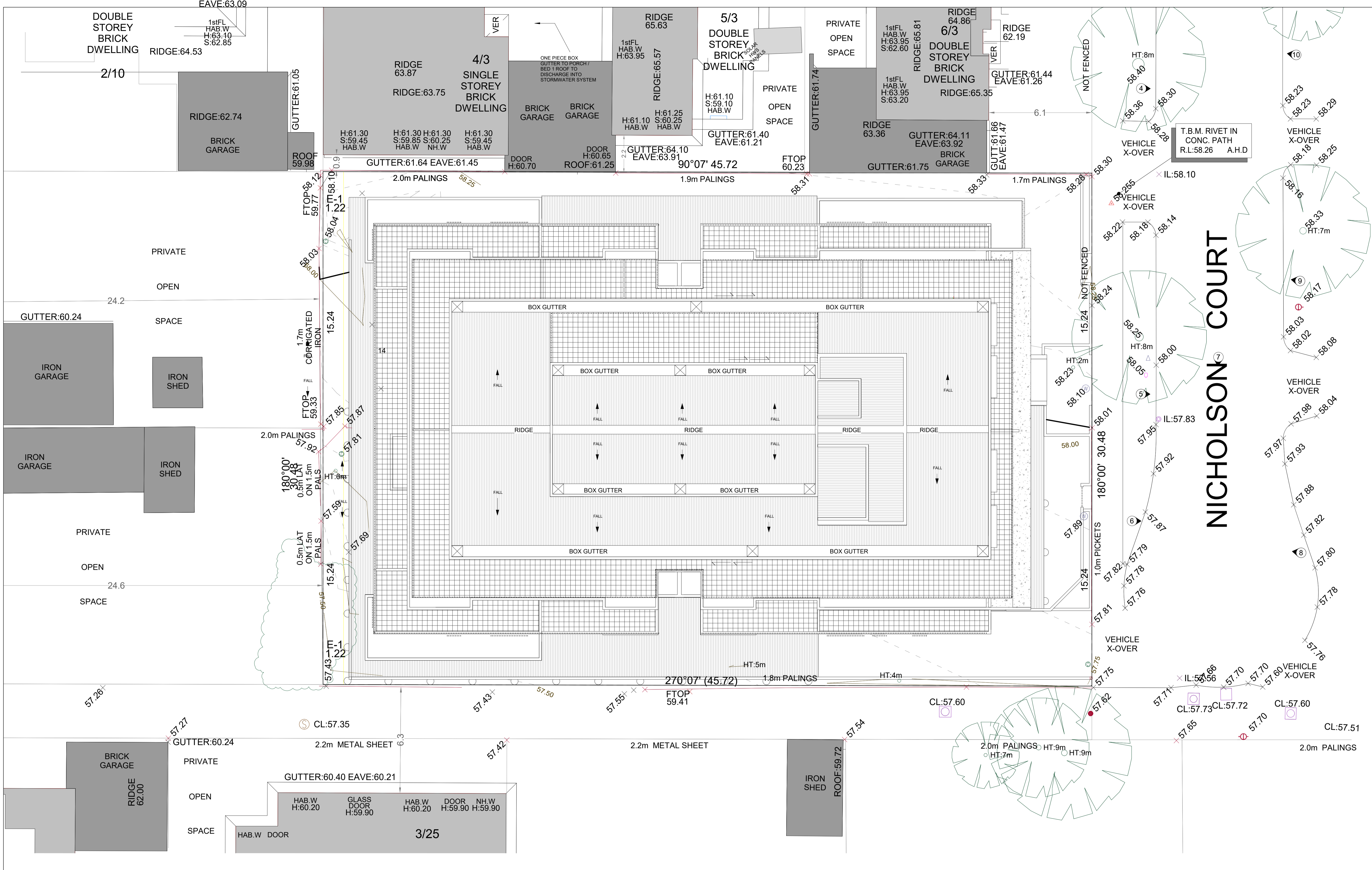

NICHOLSON COURT

Roof Plan
1:100

COPYRIGHT - ALL RIGHTS RESERVED
 THIS DRAWING IS COPYRIGHT AND CONFIDENTIAL APART FROM ANY FAIR DEALINGS AS PERMITTED UNDER THE COPYRIGHT. NO PART MAY BE REPRODUCED BY ANY PERSONS WITHOUT WRITTEN PERMISSION OF PITARD GROUP AND IS NOT TO BE USED IN ANY MANNER PREJUDICIAL TO THIS DRAWING AND ATTACHED SHEETS REMAIN THE PROPERTY OF PITARD GROUP UNLESS OTHERWISE SPECIFIED. DIMENSIONS ARE IN MILLIMETRES. ALL DRAWING CONTENT MUST BE VERIFIED ON SITE PRIOR TO COMMENCEMENT OF ANY WORK.

No.	DATE	AMENDMENT

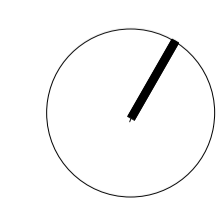

PROJECT:
7-9 Nicholson Cr Clayton
 ADDRESS:
7-9 Nicholson Cr Clayton

DRAWING:
Roof Plan

JOB NO:
2203
 SCALES:
1:100

AUTHOR:
PP
 DATE:
26-04-22

DRAWING NO:
TP-10
 A1 size sheet:

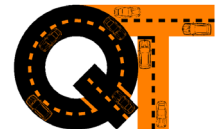

Appendix B

Swept Path Diagrams



Swept Path Diagrams

Address: 7-9 Nicholson Court, Clayton

LGA: Monash **Ref:** 2022-0080

CAR SPACE 1 - ENTRY

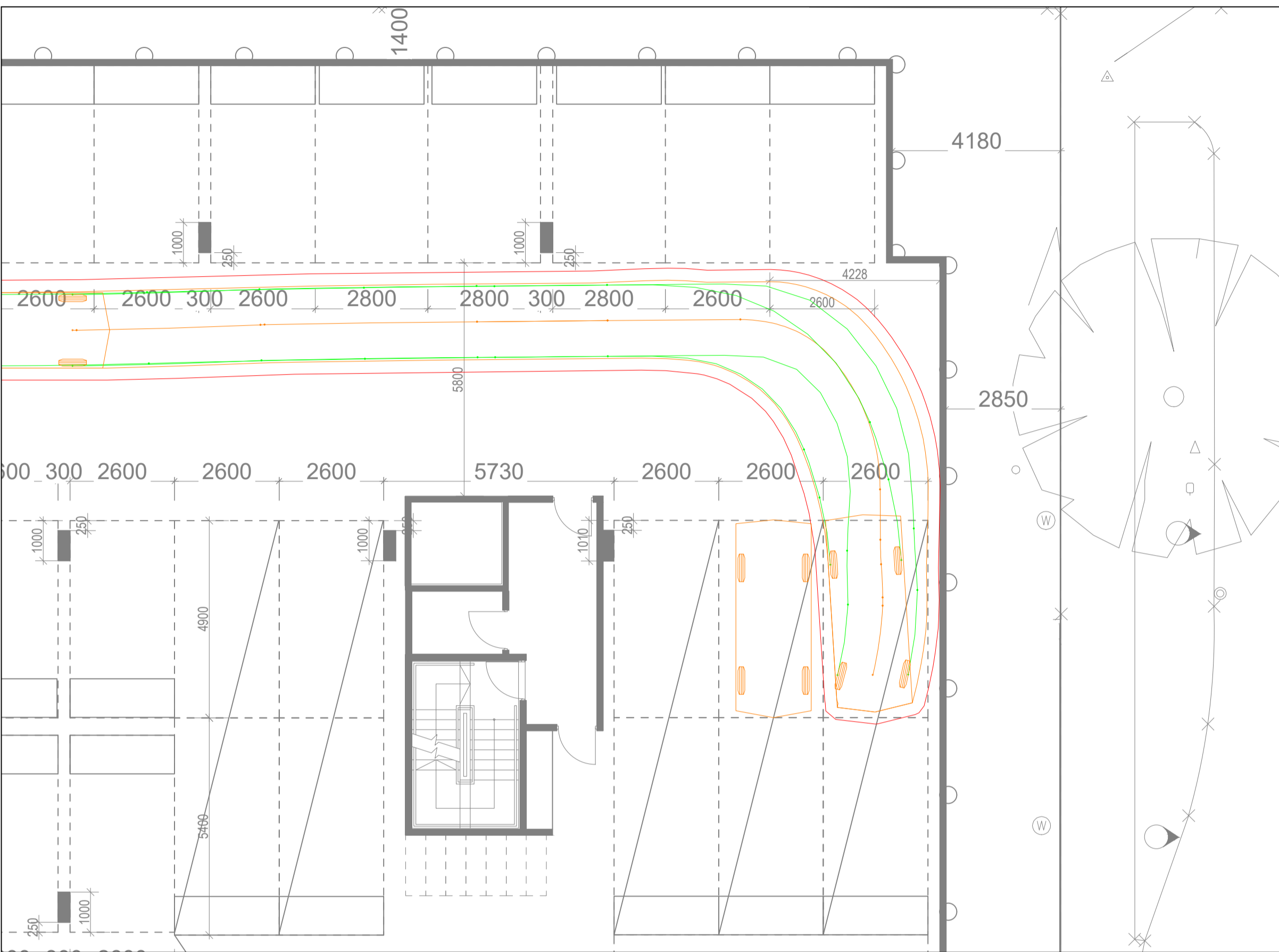

CAR SPACE 1 - EXIT

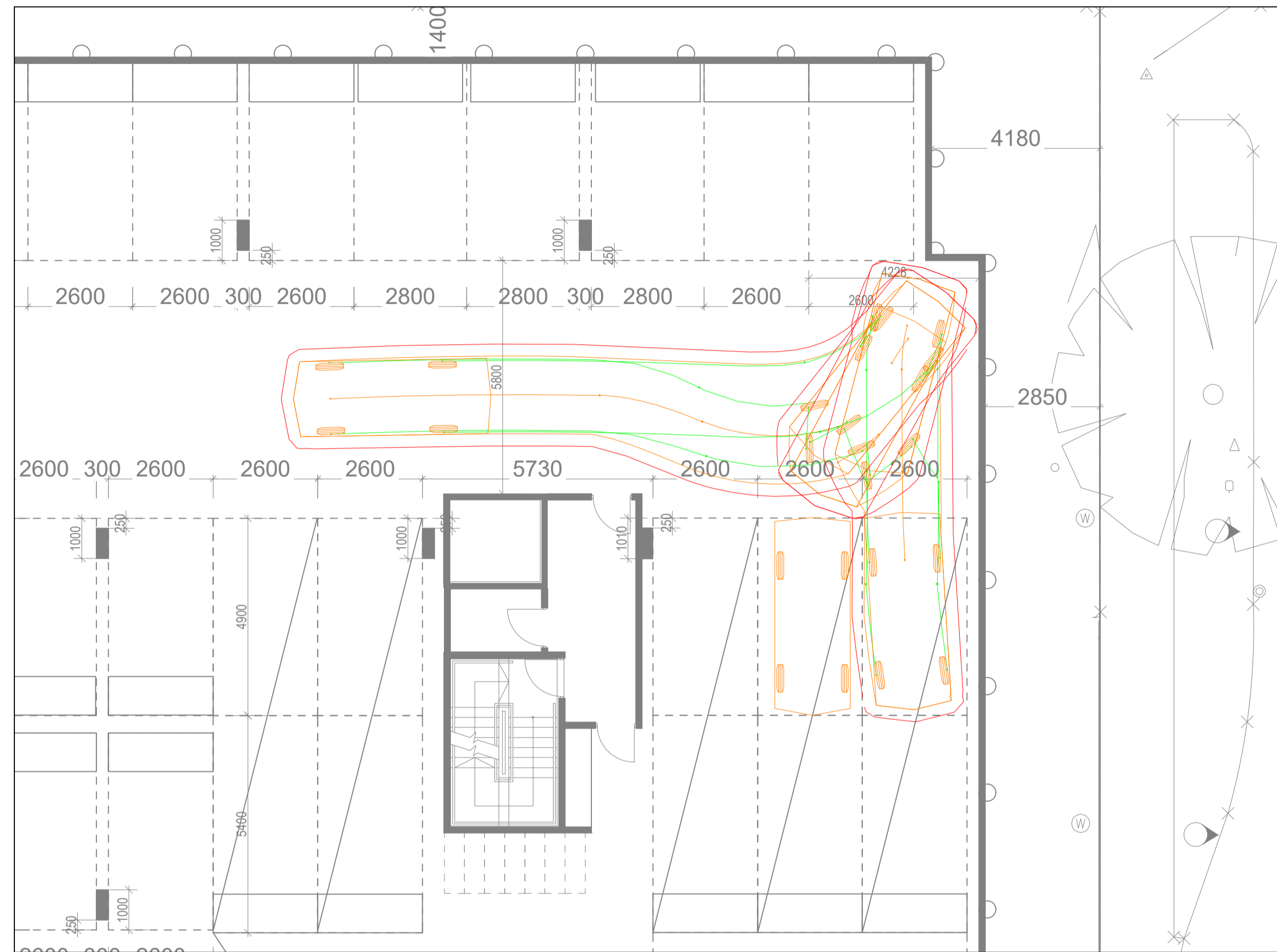

CAR SPACE 2 - ENTRY

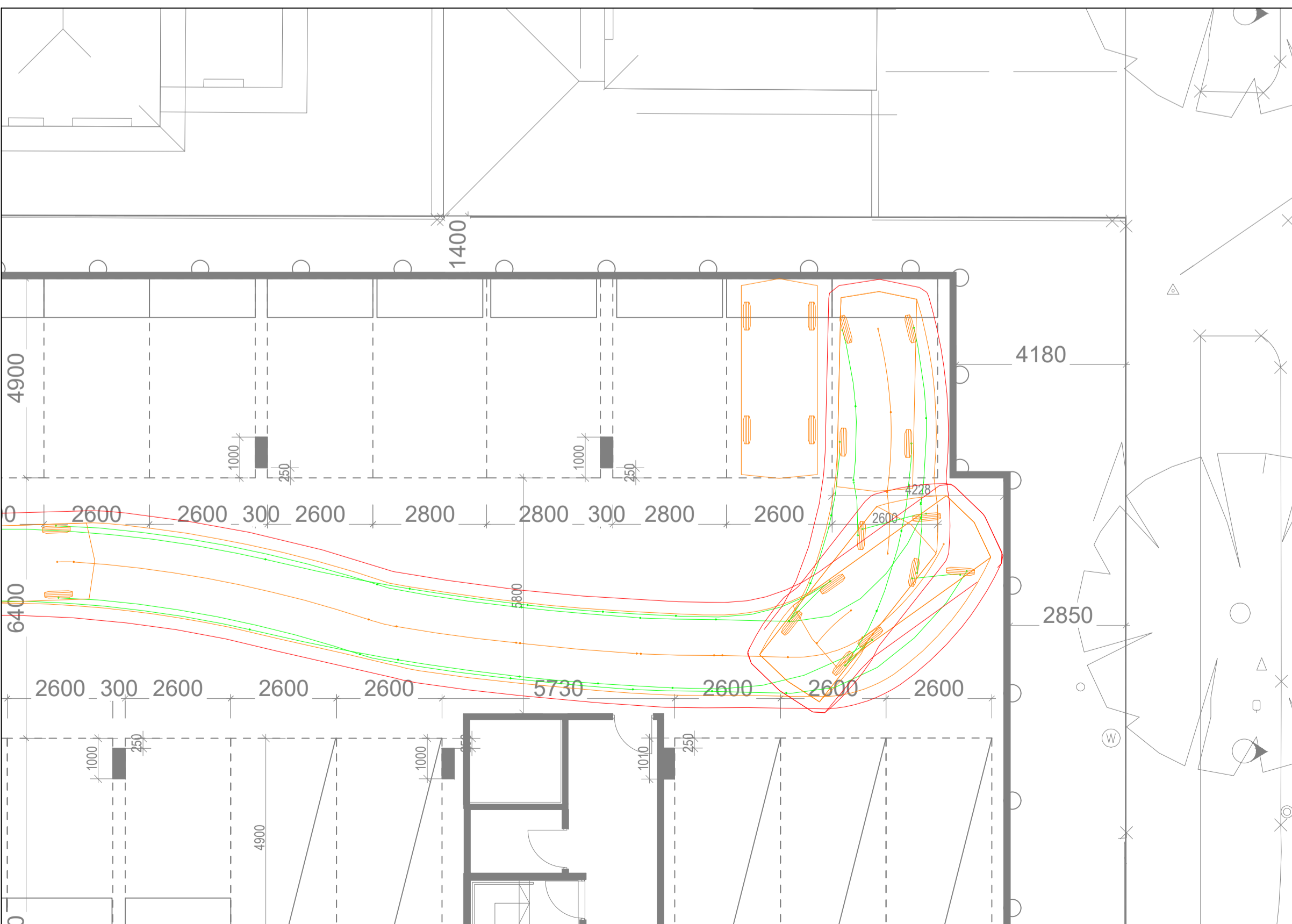

CAR SPACE 2 - EXIT

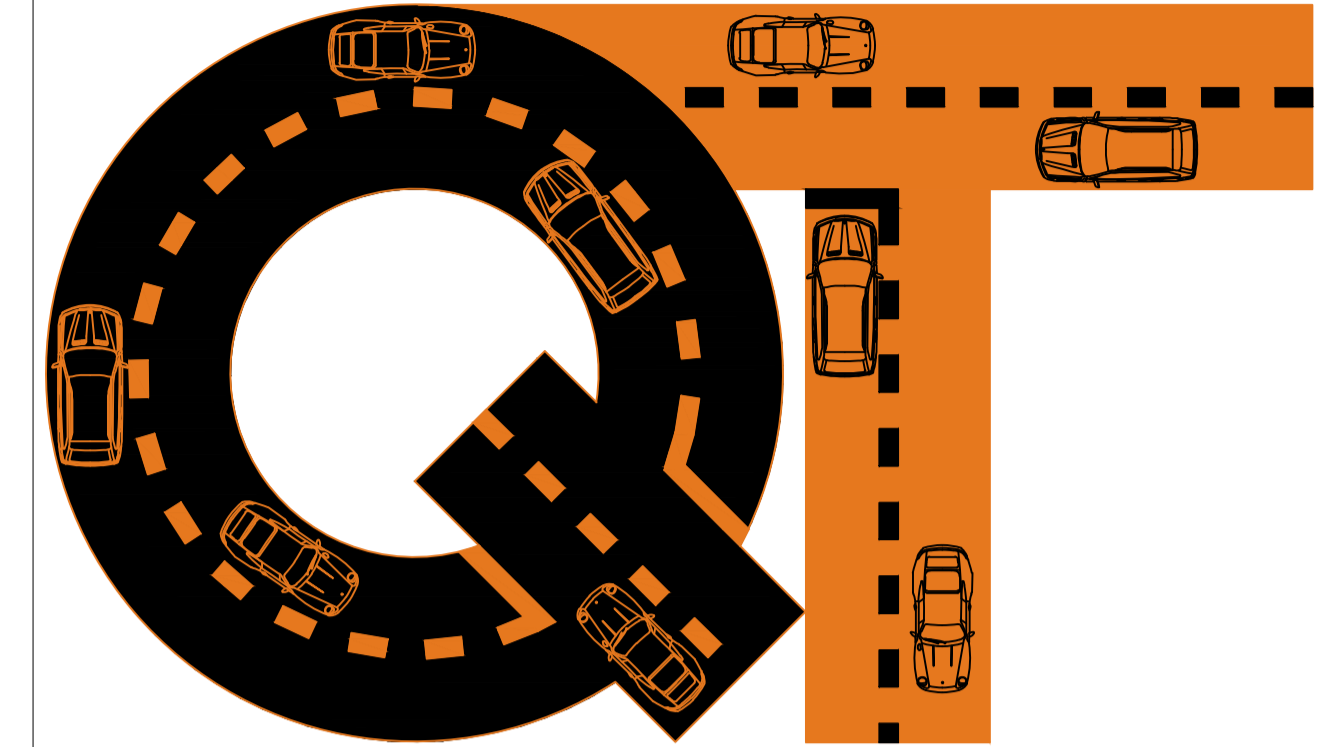
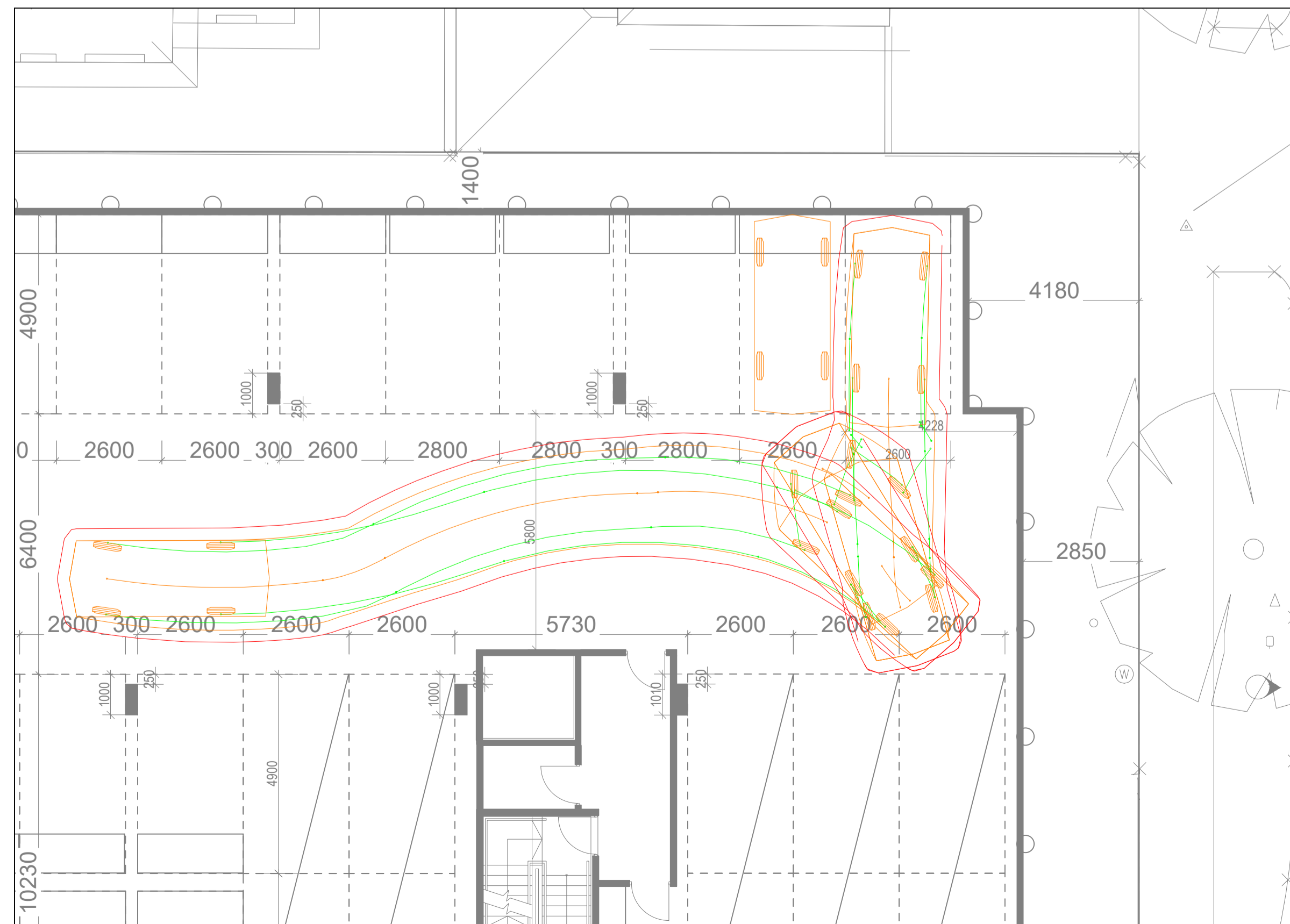

Quantum Traffic

e: admin@quantumtraffic.com.au

p: (03) 9879 4250

w: www.quantumtraffic.com.au

a: 5 Murraby Place

RINGWOOD VIC 3134

LEGEND

- Vehicle Body —
- Wheel Tracks —
- Clearance Lines (300mm) —

DESIGN VEHICLE USED IN SIMULATION

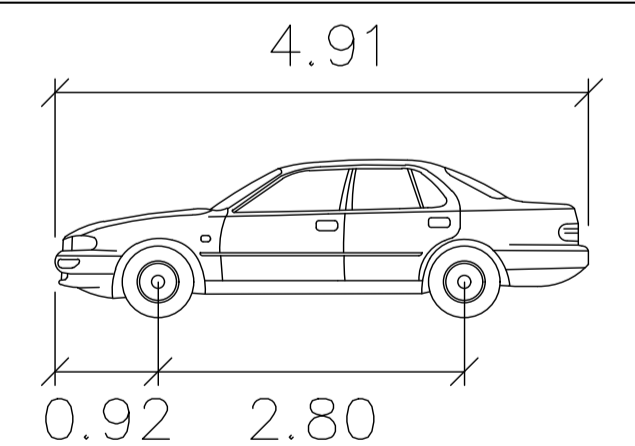

B85 Design Car - AS2890.1:2004

- Width : 1870 mm
- Track : 1770 mm
- Lock to Lock Time : 6.0 sec
- Steering Angle : 37.5 degrees
- Speed : 5 km/h

Prepared By

N.C.

Date

25/05/22

Scale A3 1:100

Swept Path Diagrams

Address: 7-9 Nicholson Court, Clayton

LGA: Monash Ref: 2022-0080

MRL ENTRY & TURNAROUND

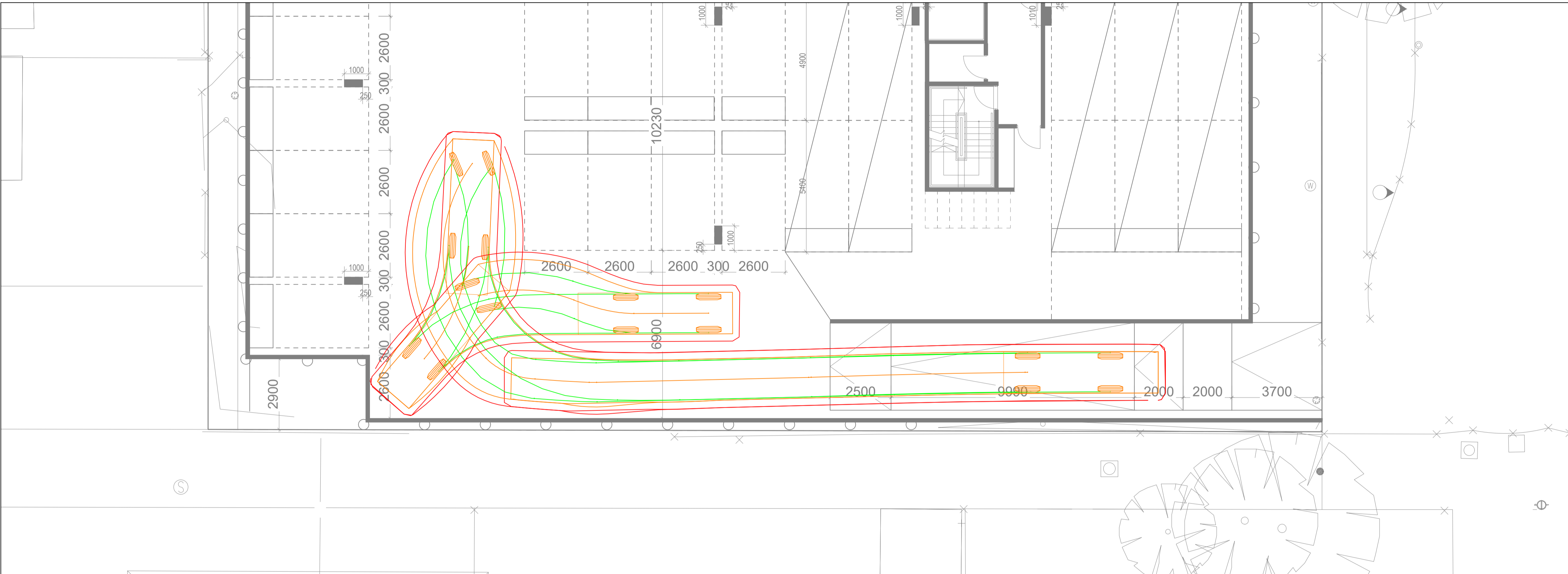

MRL EXIT

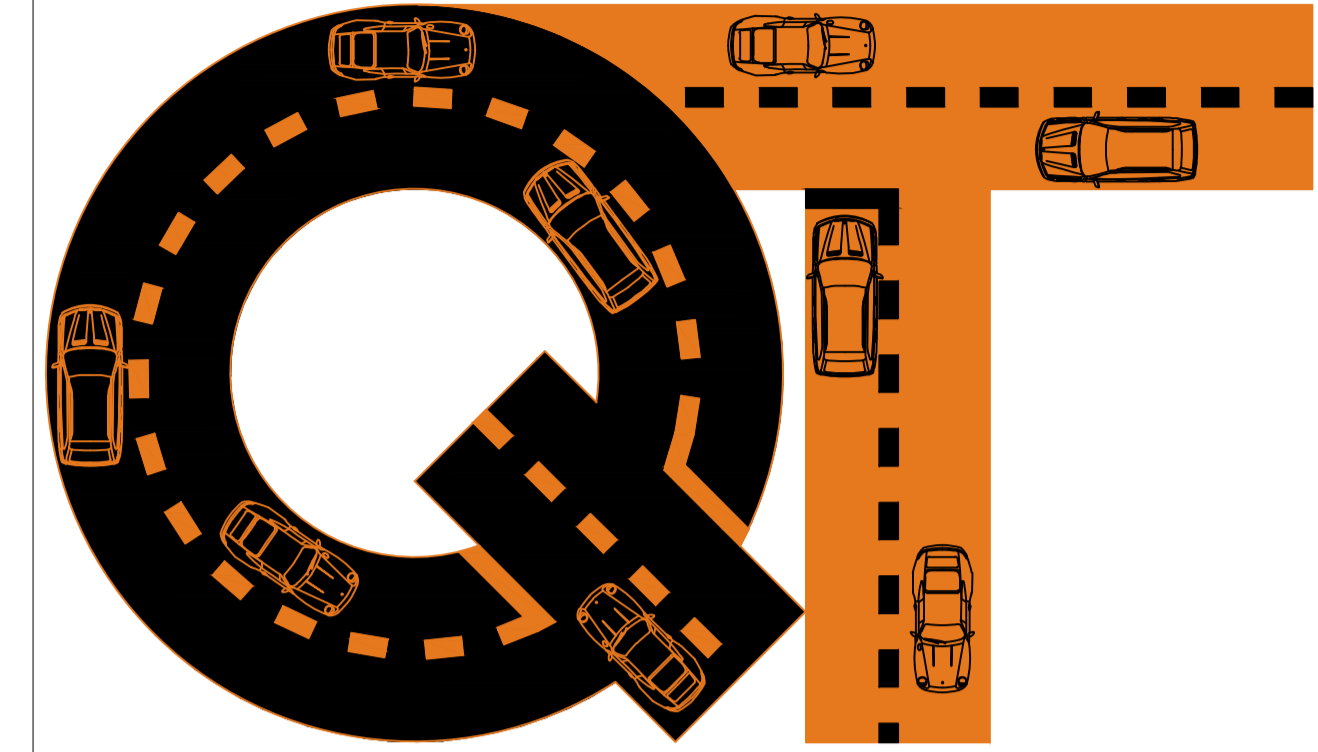
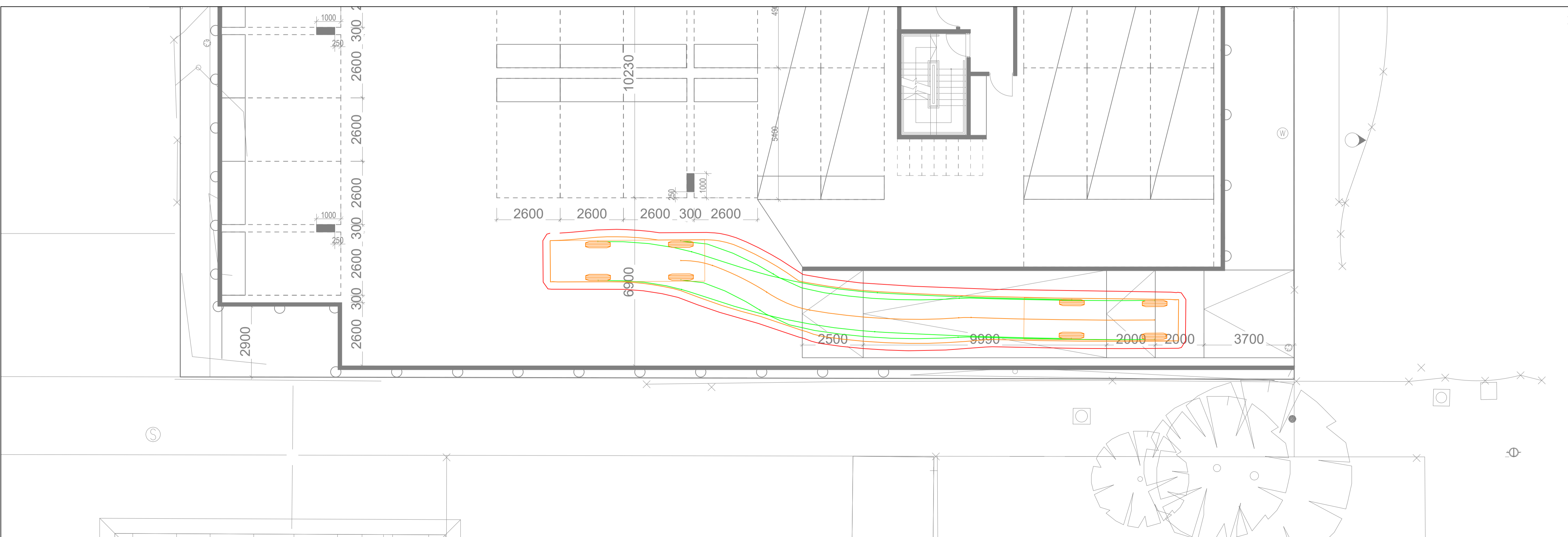

Quantum Traffic

e: admin@quantumtraffic.com.au

p: (03) 9879 4250

w: www.quantumtraffic.com.au

a: 5 Murraby Place

RINGWOOD VIC 3134

LEGEND

- Vehicle Body —
- Wheel Tracks —
- Clearance Lines (300mm) —

DESIGN VEHICLE USED IN SIMULATION

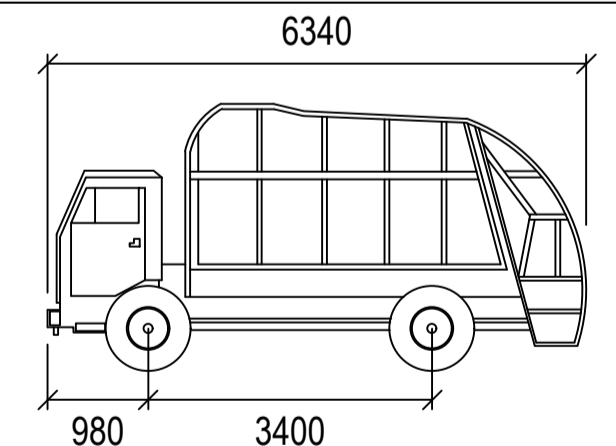

6.4m Long Mini Rear Loader

- Width : 1700 mm
- Track : 1600 mm
- Lock to Lock Time : 6.0 sec
- Steering Angle : 33.3 degrees
- Speed : 5 km/h

Prepared By

N.C.

Date

25/05/22

Scale A3 1:100