

PLAN
SCALE 1:250

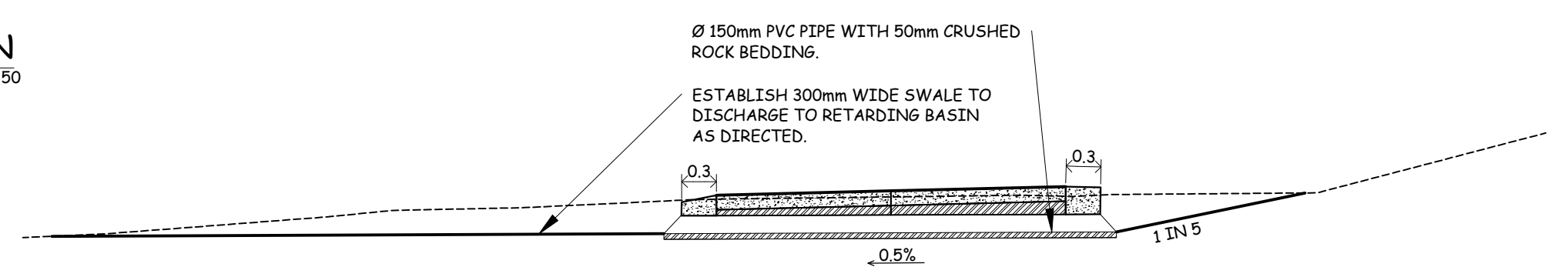

SECTION A-A
NOT TO SCALE

- 150mm THICK, SL82 REINFORCED CONCRETE
- 2% BAYFERROX BLACK CONCRETE

CHAINAGE	EXISTING SURFACE	DESIGN SURFACE	Cut/Fill	Grades
0.000	97.88	97.888	+0.011	2.535%
3.591	98.02	97.979	-0.037	12.000
6.316	98.04	98.025	-0.011	-5.000%
7.628	98.02	98.030	+0.009	25.000
9.591	98.00	98.018	+0.019	0.500%
14.005	97.76	97.903	+0.143	30.000
15.591	97.97	97.831	-0.266	0.106%
35.012	56.17	56.860	+0.689	
36.431	56.17	56.789	+0.618	
48.655	56.19	56.342	-0.149	
48.931	56.19	56.335	-0.142	
59.158	56.17	56.221	-0.050	
61.431	56.17	56.227	-0.057	
93.119	56.24	56.385	+0.141	
101.736	56.32	56.428	+0.111	
115.641	56.36	56.498	+0.142	
120.000	56.40	56.518	+0.119	
129.289	56.52	56.554	+0.039	
130.641	56.52	56.558	+0.038	
143.492	56.43	56.586	+0.160	
145.641	56.95	56.589	+0.037	
154.636	56.49	56.598	+0.108	
159.984	56.48	56.604	+0.128	
174.393	56.50	56.619	+0.122	
175.694	56.52	56.621	+0.097	

SHARED PATH CENTRELINE LONGITUDINAL SECTION
SCALE 1:250 HOR 1:50 VER

DIAL BEFORE YOU DIG
www.1100.com.au

CONTRACTOR MUST DIAL 1100 TO CONFIRM LOCATION OF EXISTING SERVICES AND COMPLY WITH ANY AUTHORITY REQUIREMENTS REGARDING EXISTING SERVICES PRIOR TO COMMENCEMENT OF ANY WORKS.

LEGEND

- CONCRETE PAVING
- ASPHALT OVERLAY
- FENCE LINE
- EX & PROP LEVELS
- EX & PROP CONTOURS
- HOUSE DRAIN
- TABLE DRAIN
- EX DRAIN & PIT
- PROP DRAIN & PIT
- SEWER & PIT
- O'HEAD ELEC LINE & POLE
- U'GRND ELEC CABLE & PIT
- WATERMAIN & FITTING
- GASMAIN & FITTING
- PHONE CABLE & PIT
- LIGHT POLE
- OHE
- CENTRE LINE
- TRAVERSE LINE
- W EX TREE OR SHRUB
- G
- T TREE TO BE REMOVED
- TBM

NOTES AND AMENDMENTS

Area reserved for notes and amendments.

CITY OF MONASH

DESIGN MANAGEMENT

SCOTCHMANS CREEK TRAIL HUNTINGDALE ROAD TO STANLEY AVENUE, MOUNT WAVERLEY SHARED PATH CONSTRUCTION - STAGE 2

SURVEY: SP/MR
DATE: APR '13
DESIGNED: BX
DATE: JUN '19
COM1782 - T - REV(4).dwg

MANAGER - ENGINEERING:
SCALE: AS SHOWN

DIRECTOR - INFRASTRUCTURE:
PROJ 1782
CONTRACT - 21456

DATUM: A.H.D.

2 OF 8